

ERA^ΔANT

NEXT GENERATION MILLIMETERWAVE COMPONENTS

CONTACTLESS WAVEGUIDE FLANGE & MMW-THZ TEST SETUP APPLICATIONS

Proxi-Flange™ and Wave-Glide™

A Patent Pending and Trademarked Technology

8 to 10 June 2021, IMS 2021 MicroApps

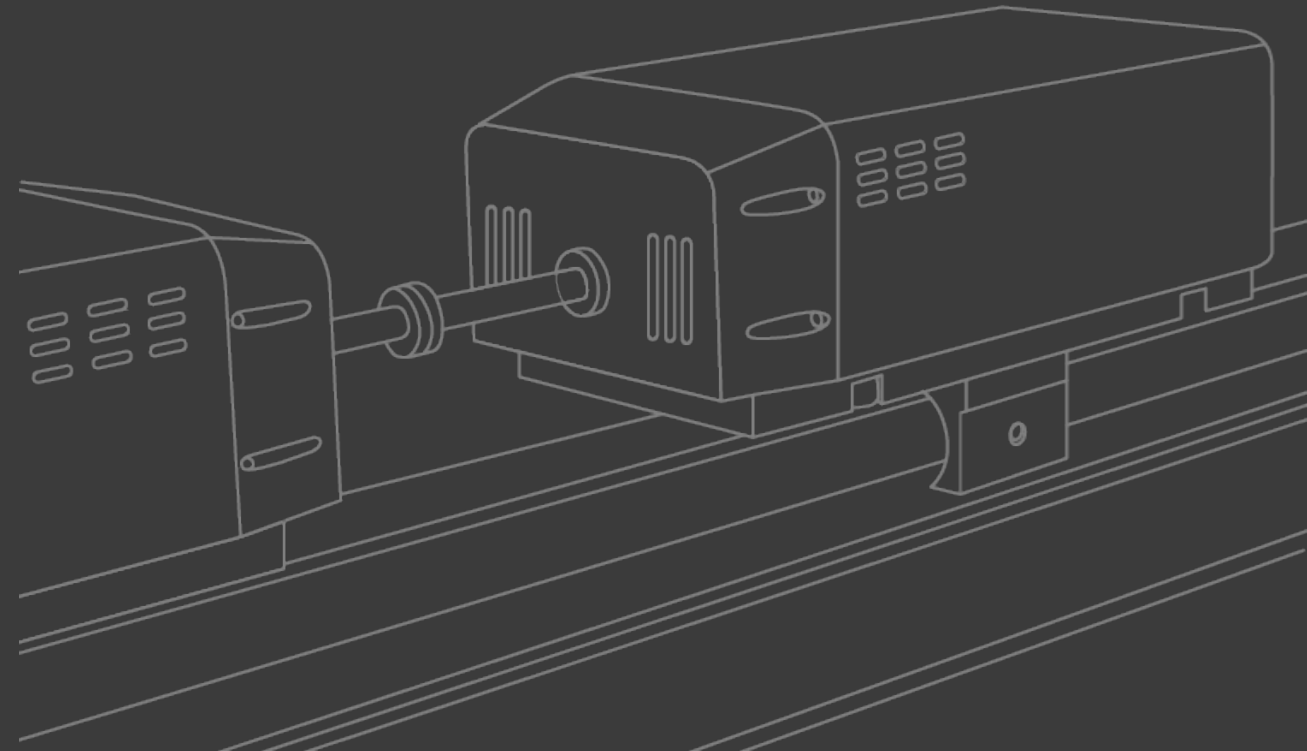

CONTENTS

INTRODUCTION

WHAT IS IT?

Proxi-Flange™

HOW WERE THEY INVENTED?

BENIFITS

CONTACTLESS FLANGE: ELECTRICAL DESIGN

CONTACTLESS FLANGE: MECHANICAL DESIGN

RAIL SETUP

Proxi-Flange™

TEST RESULTS

WEBSITE AND VIDEO

CONCLUSION

INTRODUCTION

Millimeterwave and THz

- Millimeterwave Band: 30 to 300 GHz | THz Band: 100 GHz to 3 THz and Beyond
- Rectangular waveguide is the main transmission line for low loss.

Millimeterwave and THz Measurement Challenges

- Mis-Alignment
- Waveguide Cocking
- Screw Insertion
- Waveguide Bending and Deforming
- Time consuming

These will cause the inaccurate measured data and unreliable measured data.

These can be overcome by the **Robust Contactless Waveguide Flange and Rail Setup**.

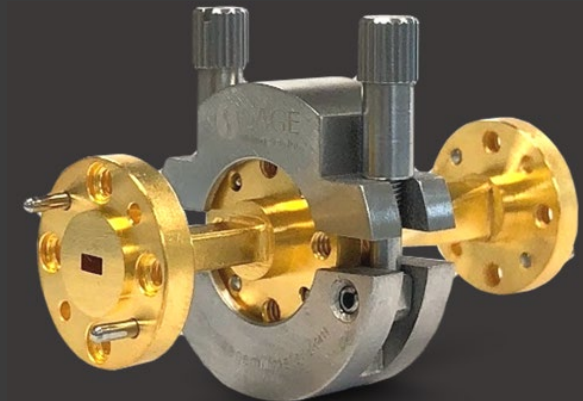

WHAT IS IT?

Two inventions in this presentation

- **Contactless Flange:** which is a waveguide section with a novel flange design which forms RF choke when making connection to other waveguide flange to eliminate the requirements of perfect mechanical contact. No perfect mechanical contact is needed. It is trademarked as *Proxi-Flange™*.
- **Rail Setup:** which is a rail structure to allow the millimeterwave VNA extenders performing an easy alignment and connection of DUT and test equipment during the [S] parameter testing when *Proxi-Flange™* is used. It is trademarked as *Wave-Glide™*.

Proxi-Flange™

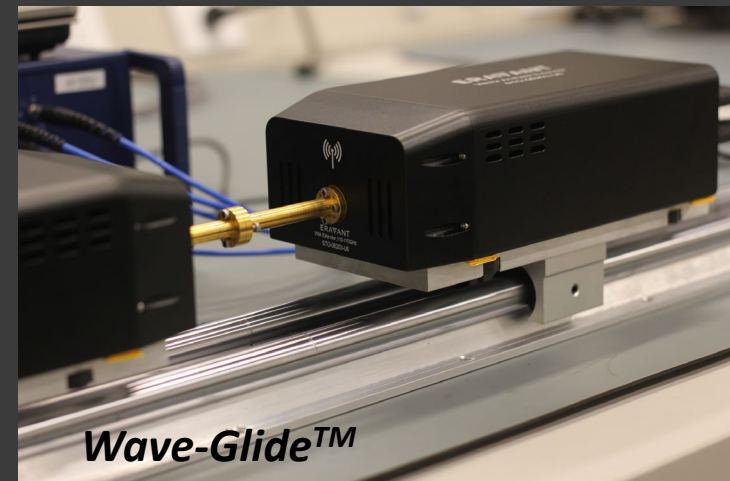

HOW WERE THEY INVENTED?

The idea was from Eravant's own millimeterwave product testing difficulties.

- Using waveguide screws to make the test set and DUT connections can leave scratches and marks on DUT surface. It also could strip the threaded holes or remove the gold-plated surface of DUT.
- Using waveguide screws to make the test set and DUT connections degrade the waveguide performance and shorten the equipment lifespan.
- Using waveguide screws to make the test set and DUT connections are time consuming.
- Improper connections between the test set and DUT by using waveguide screws, i.e., waveguide cocking can result in inconsistent or bad data.
- Tight space between the test set and DUT may make the connections between the test set and DUT difficult or impossible.
- Although the above concerns can be resolved by using Eravant *Waveguide Quick-Connect*, waveguide quick-connect requires DUT having the identical mating flange.
- To align the millimeterwave extenders and DUT is difficult and could add extra stress to the test equipment and DUT.

BENEFITS

- *Proxi-Flange™* would deliver better quality DUT products, i.e., non-worn on the flange threads and the scratch free on the flanges.
- *Proxi-Flange™* would preserve test equipment accuracy and extend waveguide test equipment lifespan.
- *Proxi-Flange™* would avoid waveguide cocking to deliver more accurate and reliable DUT test data.
- *Proxi-Flange™* would allow the tight space testing.
- *Proxi-Flange™* would make the none standard flanged DUT testing possible.
- *Proxi-Flange™* and *Wave-Glide™* would release the precision mechanical alignment stress, increase productivity and guarantee consistent DUT test results.
- *Proxi-Flange™* and the *Wave-Glide™* with built-in computer-controlled actuator or motor would address high through put, fully automated millimeterwave volume production testing demand.

PROXI-FLANGE™ ELECTRICAL DESIGN

The CST EM simulator is utilized. The detailed considerations of the designs are,

- The more rings, the higher performance. However, it is limited by the available real-estates and the machining limitation.
- The consideration of the choke ring width and pin height are selected per following criteria and later optimized by the EM simulation and iteration.
 - The width of the rings is $\lambda_g/4$ at the center frequency.
 - The height of the pins is $\lambda_0/4$ at the center frequency.
 - The figures show WR-12 Band hardware and simulated results.

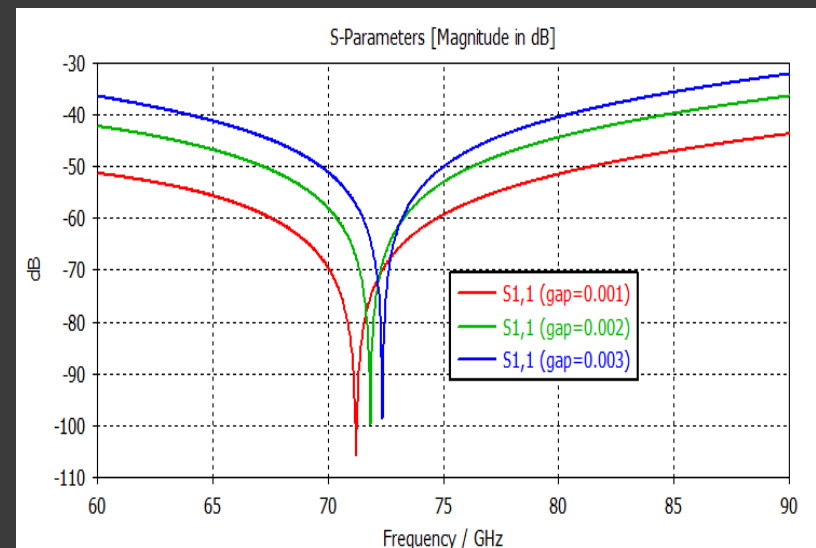
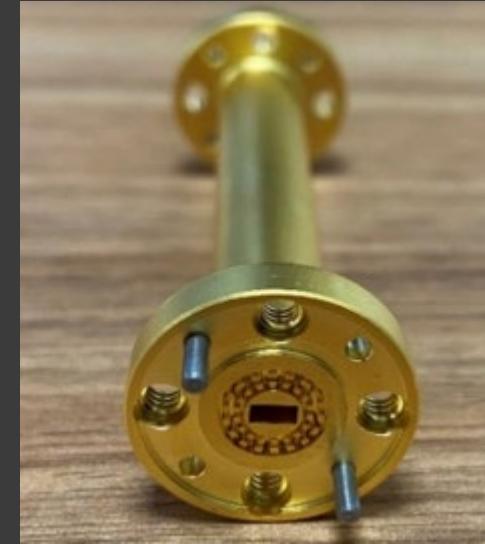

PROXI-FLANGE™ MECHANICAL DESIGN

- Anti-Cocking flange is adapted.
- Machinability is the main consideration. Back and forth electrical and mechanical iterations were performed to achieve the highest electrical performance while allowing low-cost machining process.
- Beryllium copper material is selected for durability.
- Dowell pins are remained for proper mechanical support.
- Proxi-Flange™ is gold plated for highest electrical performance.

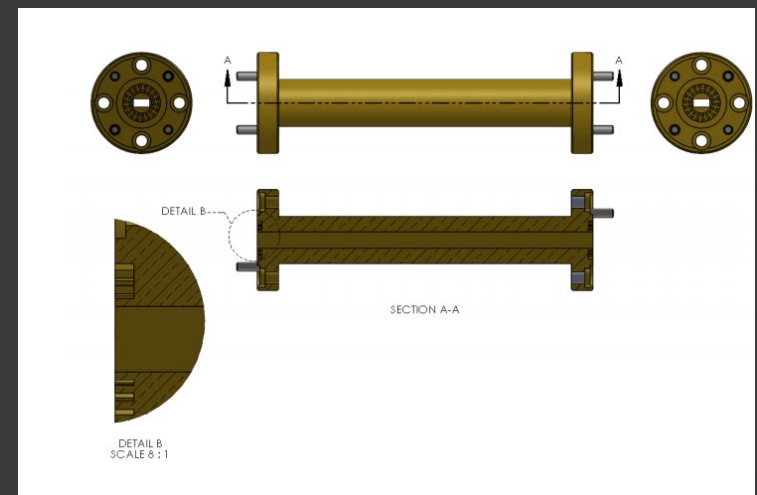
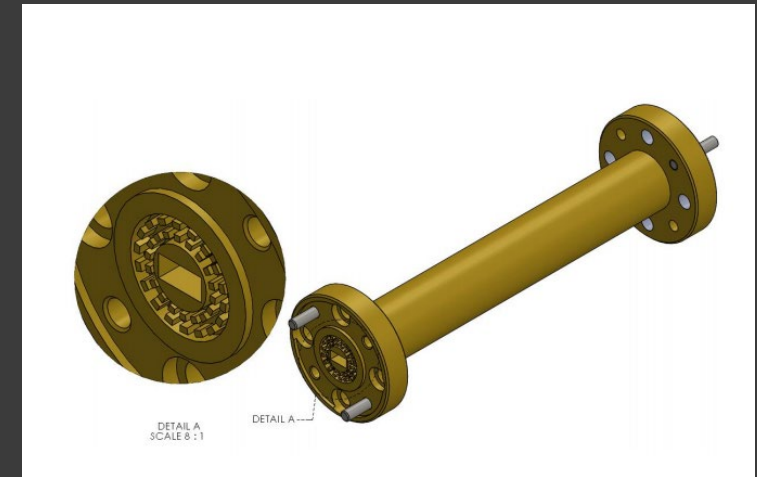

RAIL SETUP

- Rail setup is trademarked as Wave-Glide™.
- **Wave-Glide™** is invented for millimeterwave VNA test set where the linear alignment is a primary testing scenario.
- **Wave-Glide™** enhances the functionalities of the **Proxi-Flange™** to make it more practical and easier to use in millimeterwave VNA extension setup.
- Rail setup increases the millimeterwave VNA testing productivities and removes the measurement uncertainties or errors due to imperfections of conventional waveguide mechanical connections.

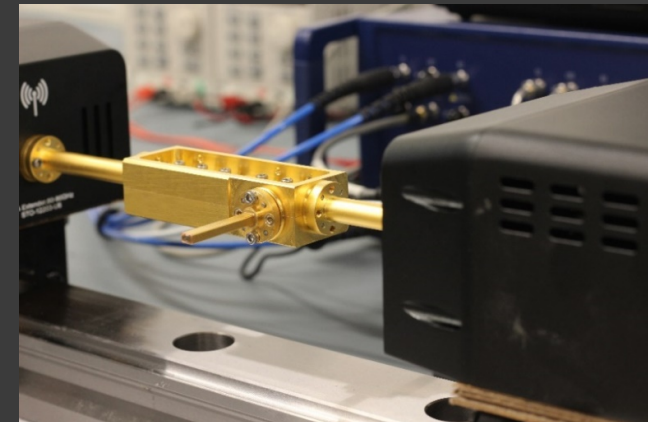
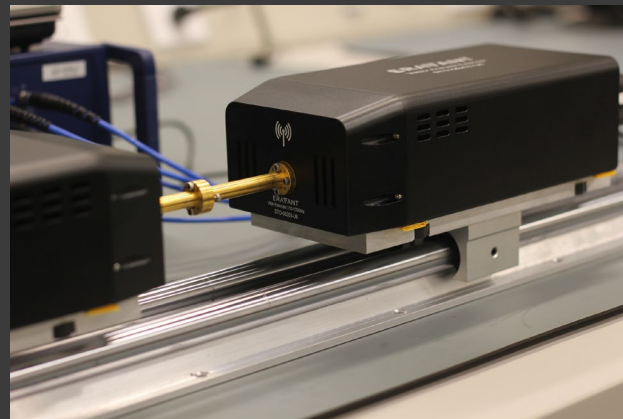
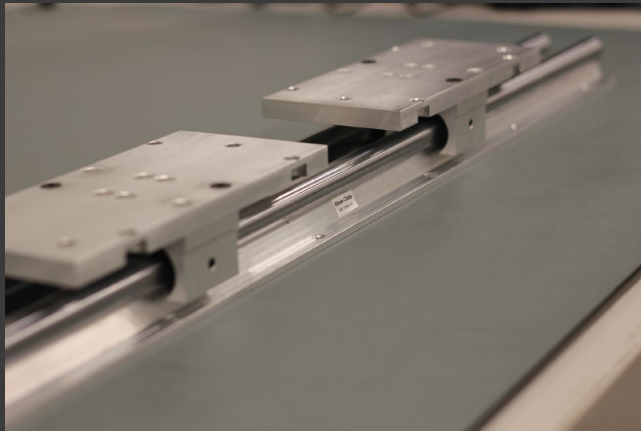

RAIL SETUP

Many rail setups are under development to offer the testing of various port configurations.

The automatic rail can be driven by computer-controlled actuators or motors to address high through put, fully automated millimeterwave volume production testing demain.

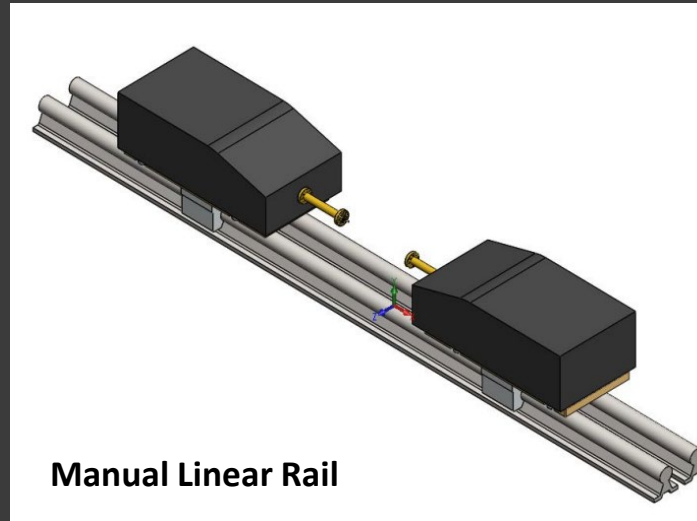

Manual Linear Rail

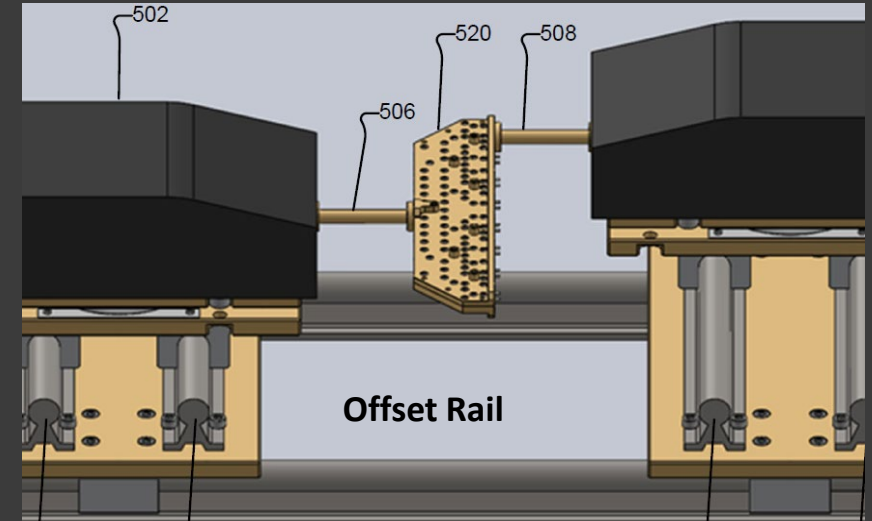

Offset Rail

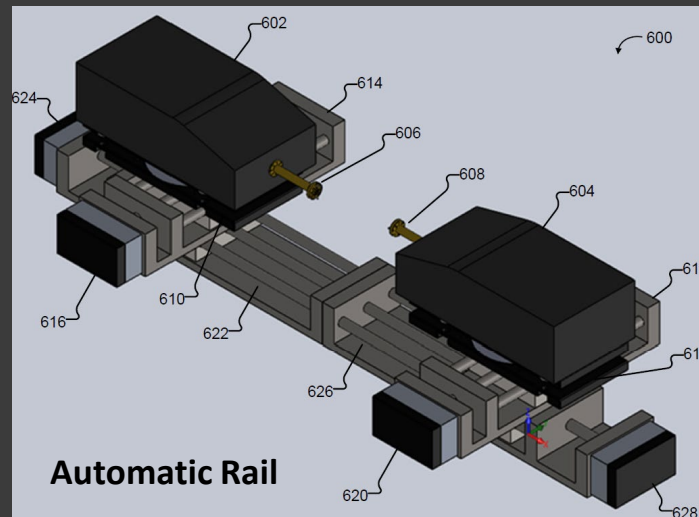

Automatic Rail

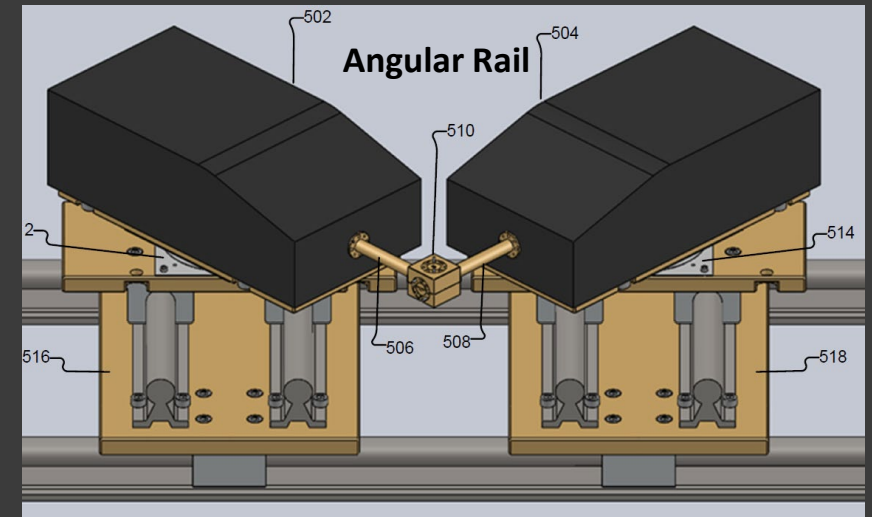

Angular Rail

TEST RESULTS

The data shown is obtained by using conventional flanged and contactless flanged waveguide.

The results show no difference between these flanged.

However, more efforts and care were needed when connect the conventional flanged waveguide to the DUT.

Insertion Loss Comparison of Insertion Loss Measurement with Conventional Flange and Proxi-Flange™ (Note: The insertion Loss of the DUT is 1 dB Typical.)

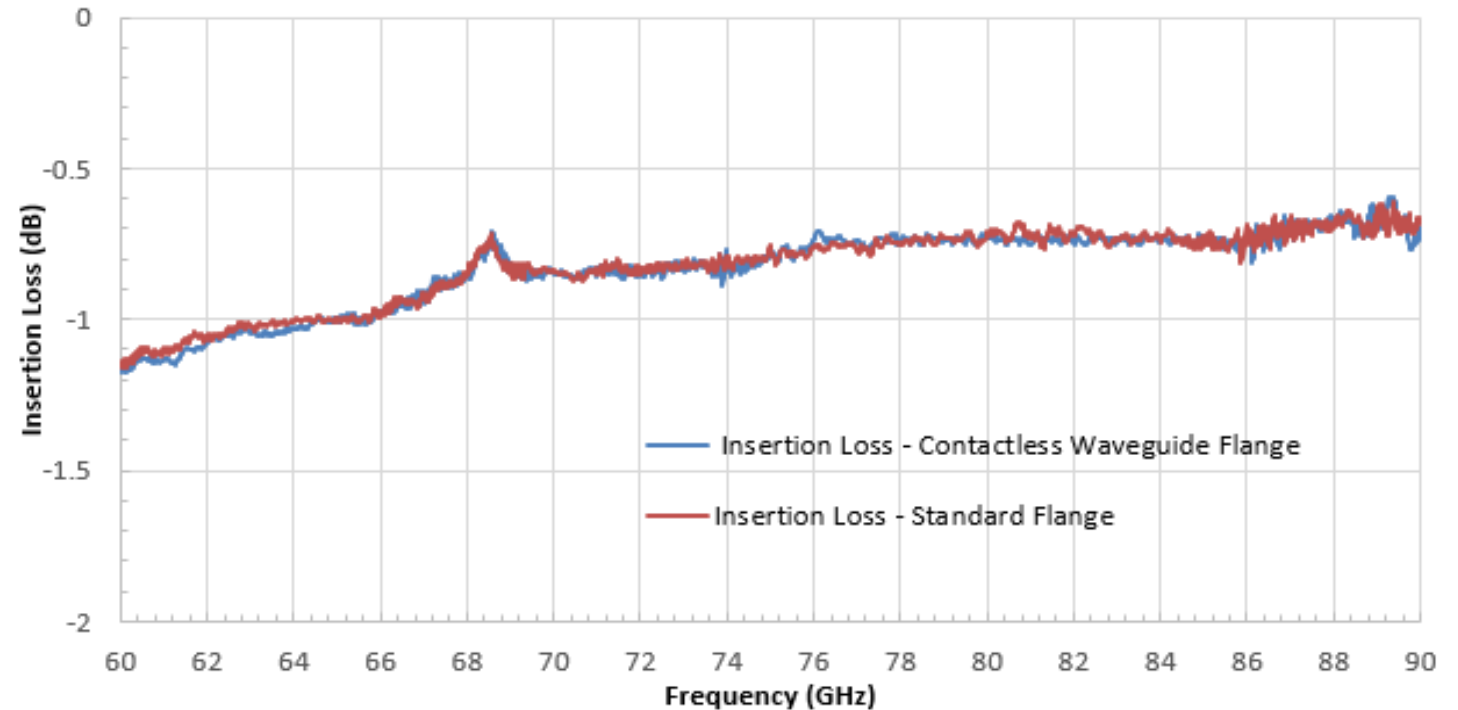

TEST RESULTS

The data shown is obtained by using contactless flange with and without waveguide screws.

The results show no difference between mechanical contact/secured and non mechanical contact/secured.

Typical Insertion Loss Comparison using Normal Flange Vs Contactless Flange for Fixed Attenuator

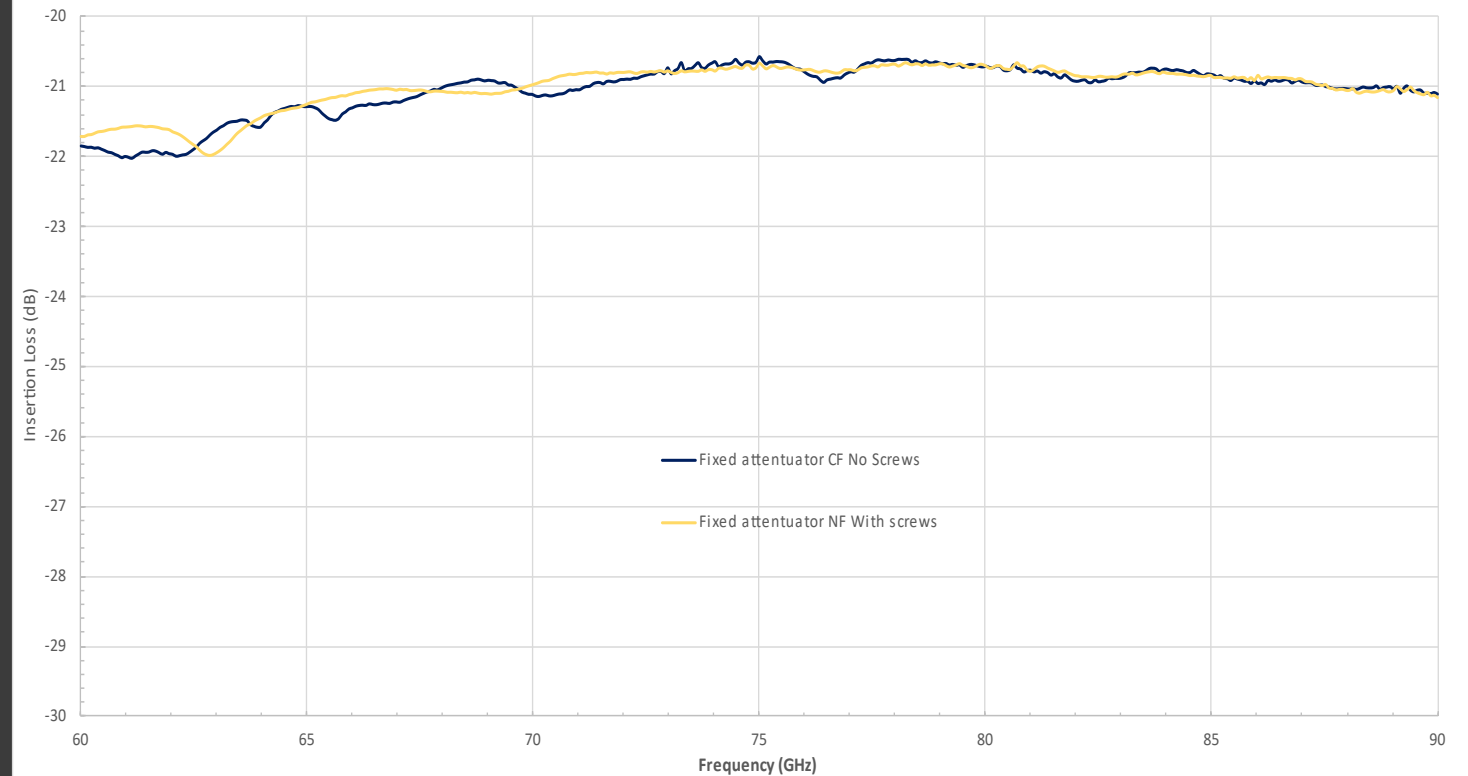

TEST RESULTS

The data shown is obtained by using contactless flange with and without waveguide screws.

The results show no difference between mechanical contact/secured and non mechanical contact/secured.

Typical Insertion Loss using Normal Flange Vs Contactless Flange for Waveguide Filter

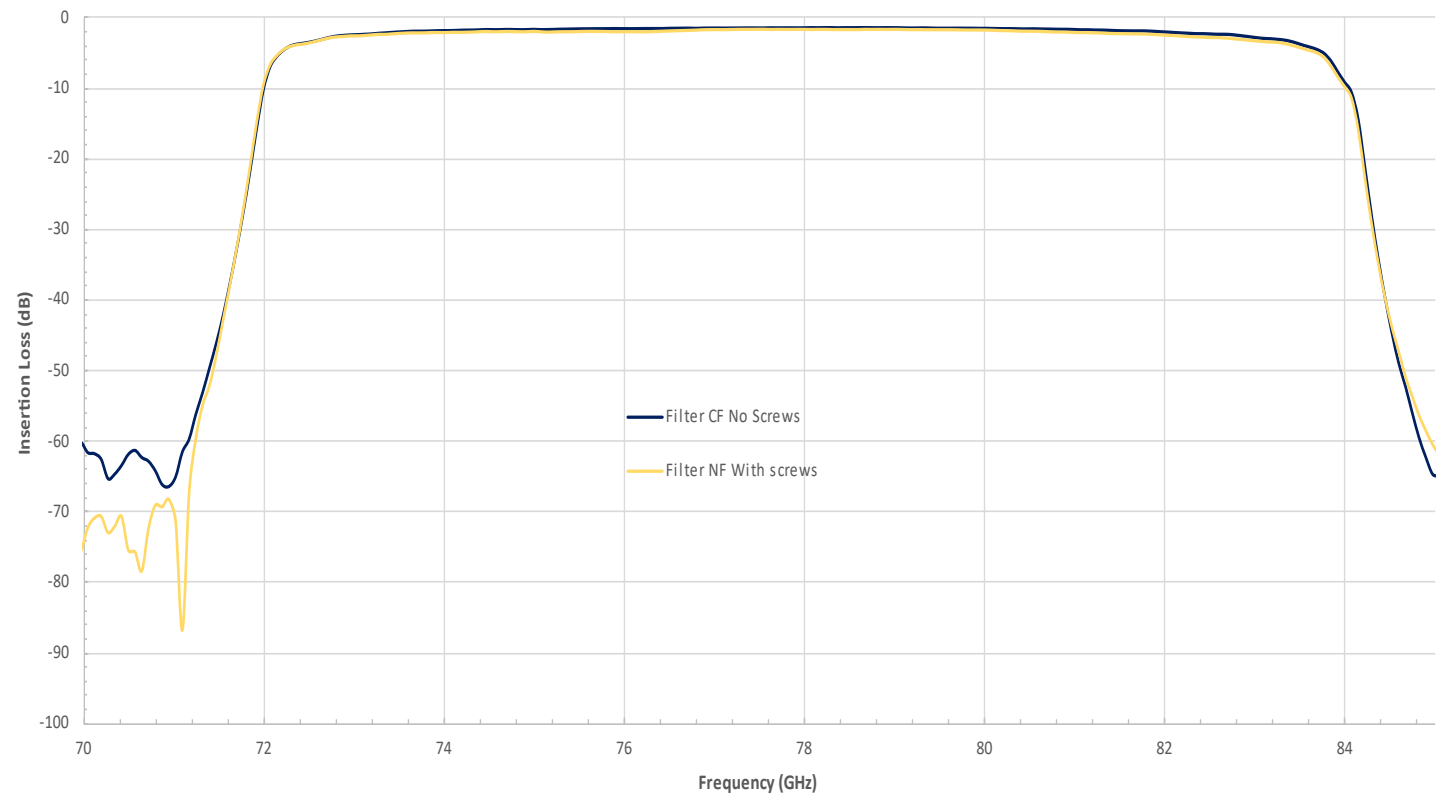

TEST RESULTS

The data shown is obtained by using contactless flange with and without waveguide screws.

The results show no difference between mechanical contact/secured and non mechanical contact/secured.

Typical Insertion Loss using Normal Flange Vs Contactless Flange for Isolator

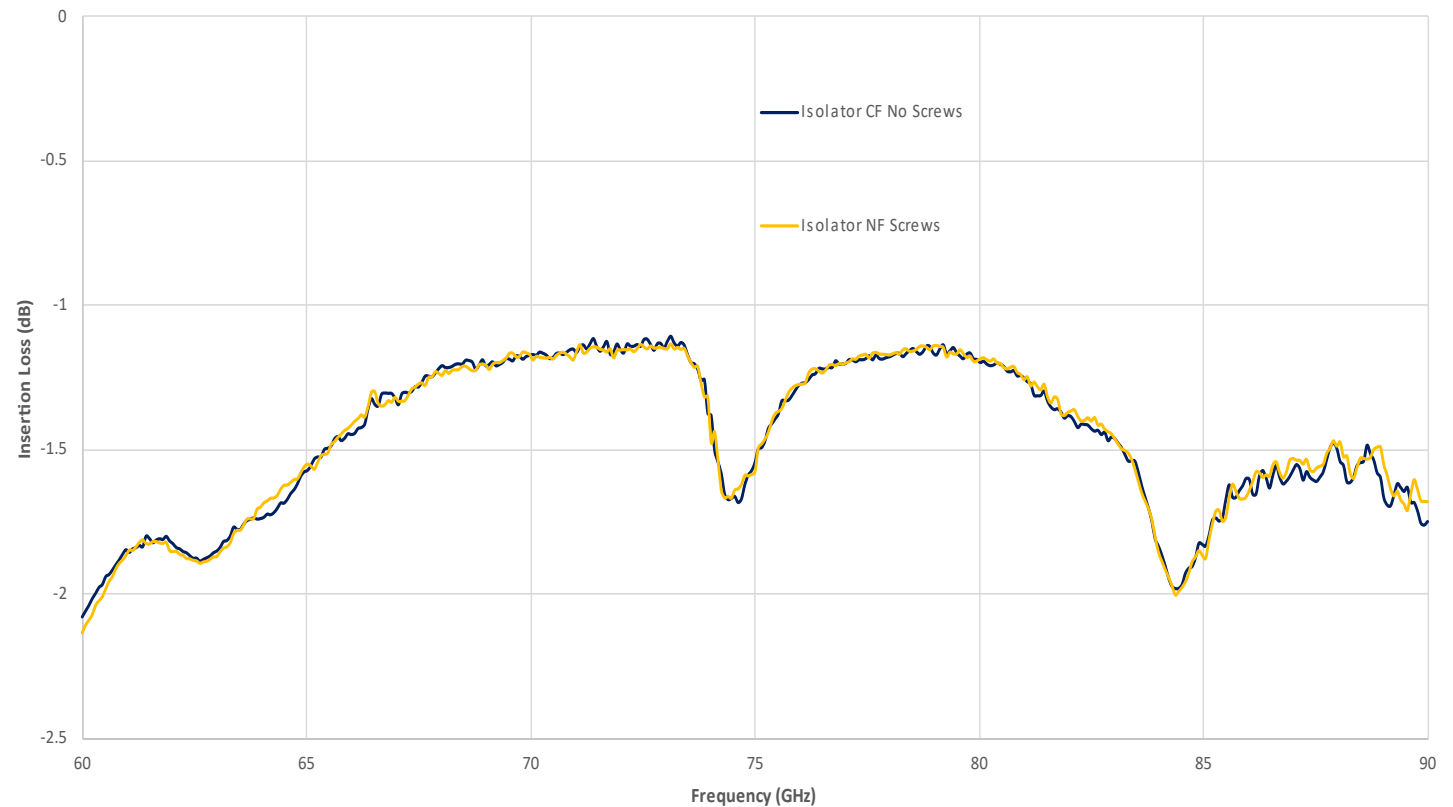

TEST RESULTS

The comparison results between the contactless flanged waveguide with and without waveguide screws in this plots shows that the worse rejection band performance, perhaps the un-even screw torque on the flange, which might have caused the cocking of the flange

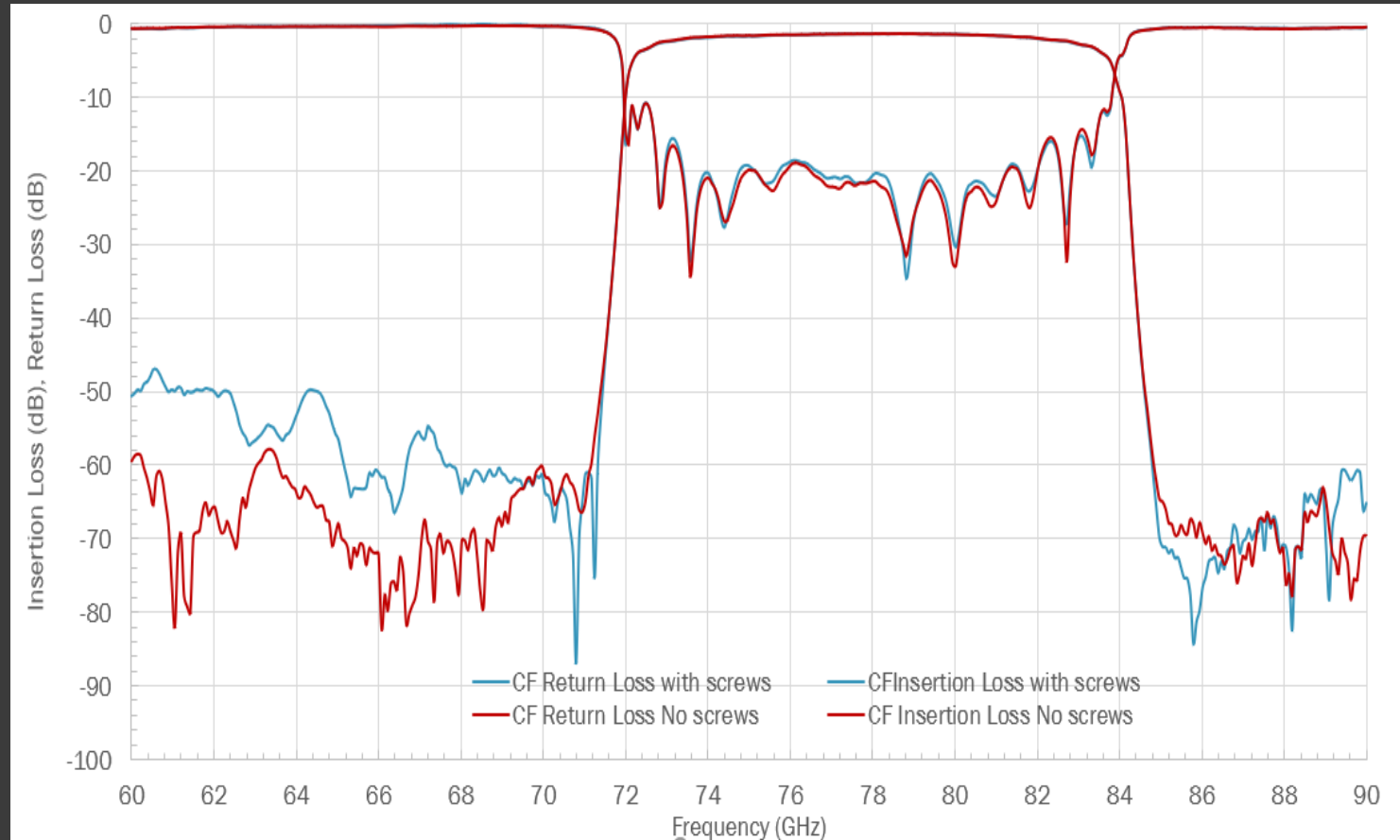

WEBSITE & VIDEO

<https://www.eravant.com/products/proxi-flange-contactless-waveguide>

VIDEO

CONCLUSION

- Contactless flange product family is developed. It covers the WR-28 to WR-05 frequency bands in the frequency of 26.5 to 220 GHz. The models for further frequency coverage development are undergoing.
- Rail setup is also developed to offer manual linear operations. The concept of automatic linear rail setup, offset rail setup and angular rail setup are proposed and further development is undergoing.
- The invention is submitted for patent application and the trademarks, *Proxi-Flange™* and *Wave-Glide™* are granted, respectively.
- The comparison test results between the contactless flanged and conventional flanged waveguide are shown and found nondifference. The difference is that the contactless flange offered effortless during the calibration and testing.
- The comparison test results by using contactless flange with and without waveguide screws are shown. The results show no difference between mechanical secured and non mechanical secured.